

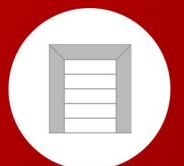

DOCK SHELTERS

DS-1111-RS

Seal off warehouse loading docks from exterior elements while loading and unloading.



RETRACTABLE DOCK SHELTERS



ENHANCE OVERALL SAFETY AT YOUR DOCKS

Dock Shelters are curtain-like enclosures that seal the gaps between the loading docks and truck trailers while loading and unloading. They work as an extension of the facility to help protect the stored goods from exterior elements like rain, dust, snow, insects, birds, rodents and other intruders. Shelters also help control the inside temperature of facilities, preventing air conditioning and heating escaping from the dock gaps.



Red Steel Retractable Dock Shelter consists of a perimeter structure with a set of canvases attached to it. These canvases adjust to fit the body of the trailer. The structure is retractable so that, in the event of an impact, the shelter will return to its original position.

Red Steel Dock Shelters are designed for durable, long lifespan, with aesthetic design and optimum water drainage features. Quick to install and easy to replace and repair parts if damaged.

This solution creates a safe, comfortable and effective environment for loading and unloading operations.

FEATURES

- 1 Polyester canvases covered with 3mm thick PVC.
- 2 Galvanized tube perimeter structure.
- 3 Vertical reflective bands for trucker visibility.
- 4 Welded top reinforcement for increased durability.
- 5 Inclined top for optimum rainwater drainage.
- 6 0.5mm thick flexible canvas covers.



Structure

The robust hinged frame design provides protection against damage from vehicles. Manufactured using 16 gauge galvanized tubes, joined by galvanized bars and covered with a 0.5mm PVC canvas. This canvas is very strong, due to its flexible polyester inner mesh.

The structure has an incline in the top of the shelter to prevent water from accumulating in case of rain or melting snow.

Canvas

Side canvases are made of woven polyester fabric, featuring screen printed stripes for max visibility. They are covered with 3mm thick, knock and friction resistant PVC.

Top canvas has a welded reinforcement that prevents tearing from harsh weather conditions. This increases durability and allows it to adjust perfectly to trailer.

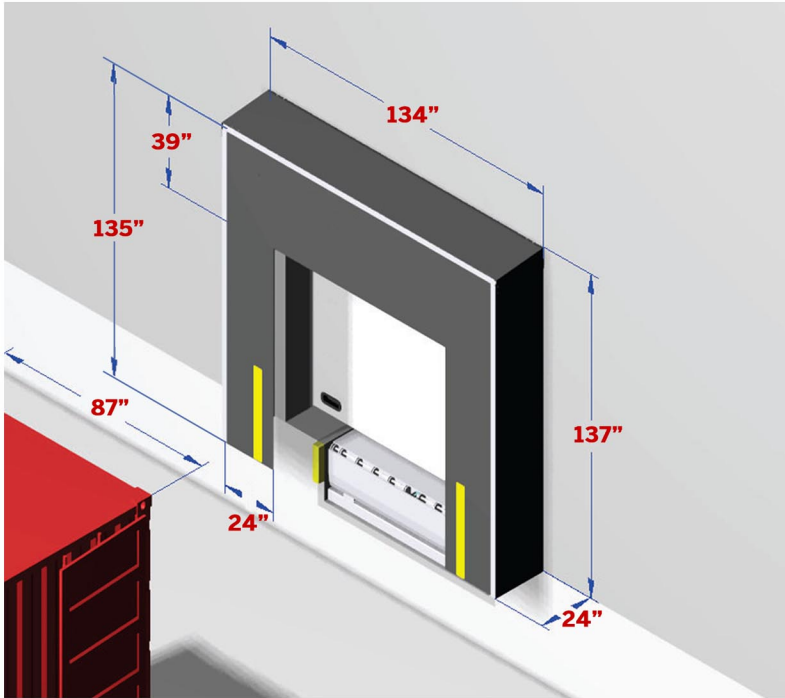
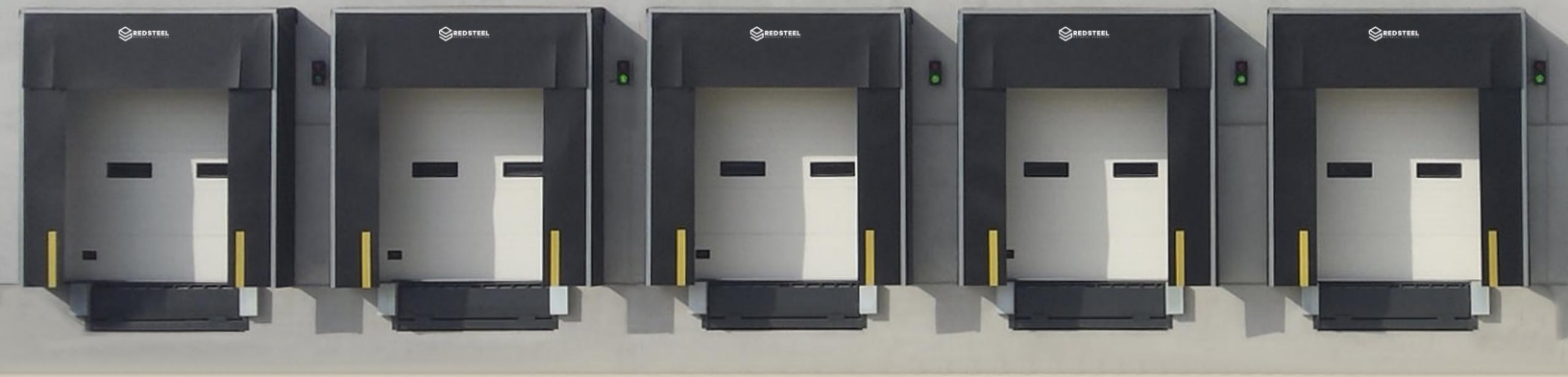

DIMENSIONS

| | IN-STOCK | LEAD TIME |
|--------------------------|----------|--------------------------------------------------------------------------|
| WIDTH | 134" | 118, 122, 125 in |
| HEIGHT | 137" | 118, 122, 126, 130, 134, 141, 145, 150, 154, 157, 162, 165, 169, 173 in* |
| DEPTH | 24" | 28, 31, 35, 39 in |
| SIDE CANVAS WIDTH | 24" | - |
| TOP CANVAS WIDTH | 39" | 47, 59, 79 in |

* For other specific measurements please consult customer service at info@redsteelmh.com



Shelter features a 10% inclined slope for water drainage.

Shelter provides high level of insulation inside the facility to preserve inner temperature.



OPERATION

When truck approaches the Dock, Shelter canvases adjust to fit the body of the trailer.



Phone: +1 (786) 475 4771
Toll Free: 1 844 287 0807
Email: info@redsteelmh.com

www.redsteelmh.com